

S/95

Automatic hamburger and meatball forming machine



RECORDS FOR SPEED, HYGIENE AND PERFECTION

2,400 hamburgers per hour, 40 hamburgers per minute. Or 4,800 meatballs per hour, 80 per minute. This is the most extraordinary performance feature of the **S/95**, but not the only one. The Nilma automatic forming machine also serves to prepare hamburgers and meatballs in the exact weight desired, with a perfect presentation and a guarantee of absolute hygiene. Consisting of a loading bowl and interchangeable rotating cylinder, the **S/95** serves to shape hamburgers and meatballs, regulating the weight in relation to the

thickness. The self-cleaning scraper wire and the automatic product discharge belt permit practical operation and labor saving.

These are the reasons why the **S/95** is one more right answer from Nilma to your demands of high productivity.

Nilma
LA SCIENZA DELLE GRANDI CUCINE

S/95

Automatic hamburger and meatball forming machine

>> THE FEATURES

>> STRUCTURAL

- >> Loading bowl, lid, motor/cylinder casing and support for conveyor belt in stainless steel 18/10 with satin finish.
- >> Base, load-bearing structure, mixing paddles and shaping cylinder in anticorodal castings suitable for food processing.

>> FUNCTIONAL

- >> Safety device on lid of loading bowl and protective casing of shaping cylinder.
- >> Interchangeable shaping cylinder, with thickness adjustment device.
- >> Mixing paddles, loading bowl, safety casing, discharge belt and shaping cylinder all manually removable for cleaning.
- >> Automatic scraping device on shaping cylinder and fixed scraper on product discharge belt.
- >> Product discharge belt in plastic material suitable for food processing, equipped with tightening mechanism.
- >> Self-cleaning scraper wire with automatic rotation.

Technical data

- Gearmotor unit powered at 0.4 kW-V 230.150Hz.
- Low voltage control panel, protected at IP 54 level.
- Hourly production:
 - hamburgers Ø 100mm, 2400 pieces/hour, (standard).
 - meatballs Ø 40mm, 4800 pieces/hours, (accessory).
- Capacity of loading bowl: 22 lt.
- Length of discharge belt: 430 mm.
- Machine weight: 65 Kg.

Technical drawings

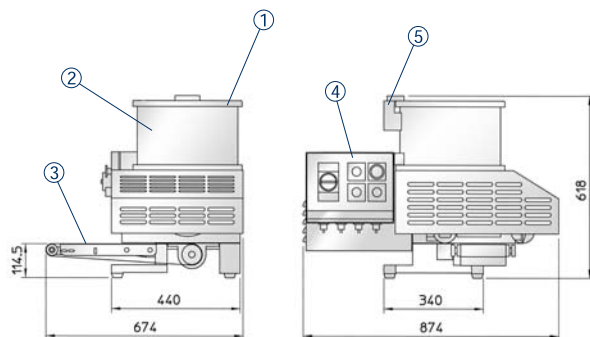

Legend

- 1) Cover 2) Loading bowl 3) Belt
4) Control panel 5) Safety device.

>> ACCESSORIES

- >> Moulding disk with two holes for meatballs, diameter 40 mm. Other shapes on request.



Moulding disk for meatballs Ø 40