

SPEEDY CUTTER

Universal food processor

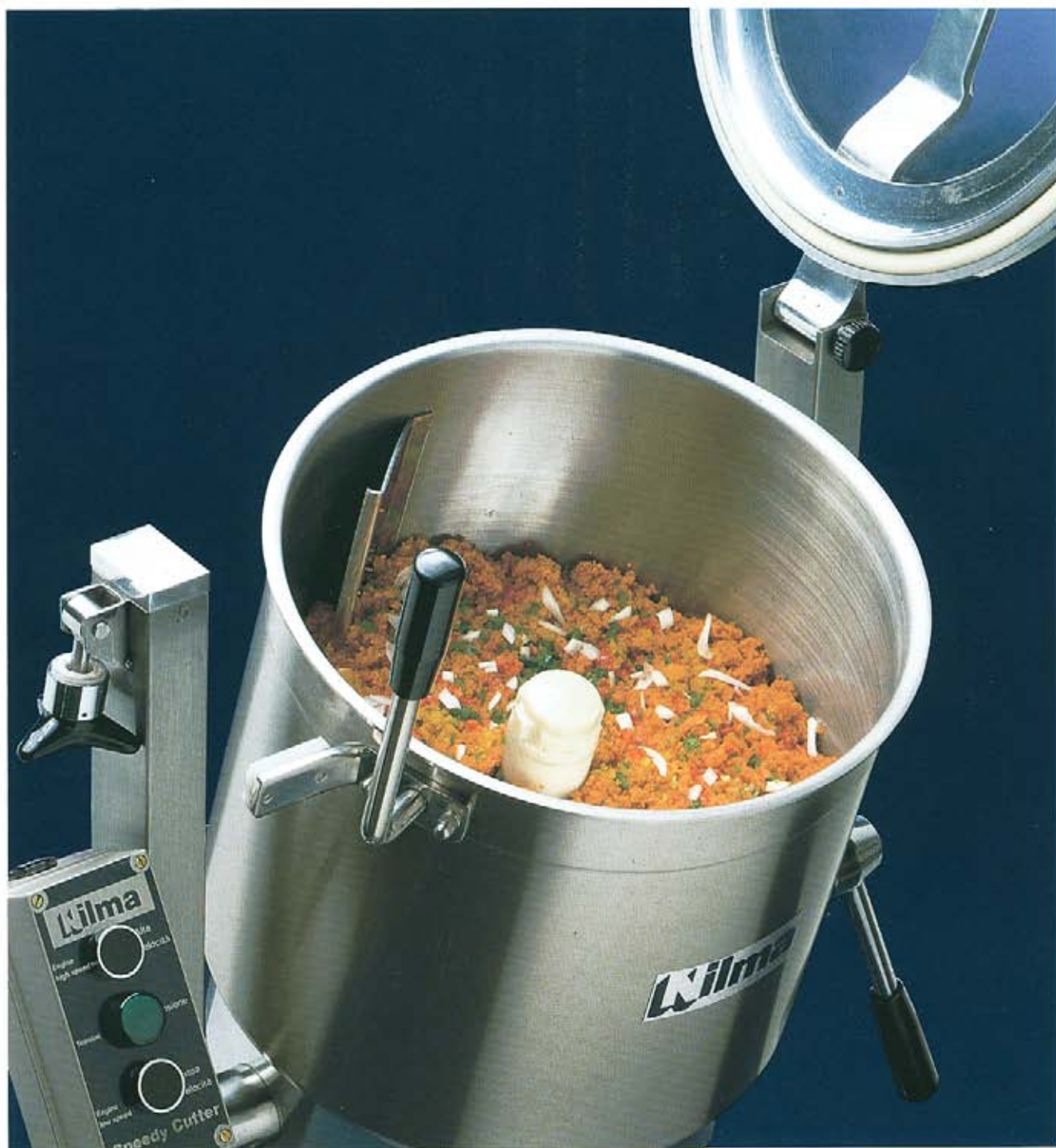

SO MANY PROCESSES ON THE ONE MACHINE

Mincing, grating, chopping, mixing are all operations which normally require a whole battery of equipment which is rarely automatic even though it may not be entirely a manual operation, as is still the case in the kitchens of many restaurants and small organizations. All this involves a considerable waste of time and therefore of money which also slows down the work of the kitchen. With the Speedy Cutter, Nilma has designed a machine to overcome all these problems,

incorporating a multiplicity of functions which it carries out extremely quickly and efficiently. The Speedy cutter transforms the preparation of mayonnaise or mincemeat, bread crumbs and grated cheese, chopping vegetables for soups, stuffings or sauces into simple operation, which can be carried out in a trice, with the additional guarantee of absolute hygiene and the advantage of more rational organization in the kitchen.

Nilma

LA SCIENZA DELLE GRANDI CUCINE

Speedy Cutter, the indispensable complement for every kitchen

Two blades for a hundred jobs

The operation of the Speedy Cutter is based on the action of a special knife with two blades, one at the bottom of the bowl and the other a few centimetres higher. The rotating blades cut the product, simultaneously generating a circular movement which throws the suspended substances on to the walls of the bowl so that they fall back on to the blades. In addition, the Speedy Cutter has two speeds: the first, a low starting speed, the second a finishing speed. By varying the times and use of these two speeds it is possible for the Speedy Cutter to:

- **Mince** any type of meat, raw or cooked, and during processing other ingredients can be added, such as eggs, cheese, bread crumbs, spices; giving a perfectly smooth mixture suitable for **hamburgers, rissoles and fillings**.
- **Grate** stale bread or even cheese.
- **Chop** any type of ingredient, from vegetables for the soup and mixtures of onions, herbs and bacon for frying, to almonds or chocolate which can be reduced to grains or flakes for the preparation of confectionery.
- **Beat** up eggs, cream, margarine, with other ingredients too, to make mayonnaise, sillabub and all types of whipped cream.
- **Liquidize** all types of fruit without leaving any lumps.
- **Strain** vegetables, adding other ingredients if required. In addition to the traditional vegetable soups it is possible to make an excellent mashed potato and any type of sauce with a vegetable, meat or fish base.
- **Homogenize** all types of vegetables, meat — beef, veal, chicken — or fruit. The various substances are finely and smoothly minced and blended so that they are easier to administer and digest; it is precisely this function which makes the Speedy Cutter indispensable in the kitchens of hospitals and nursing homes.

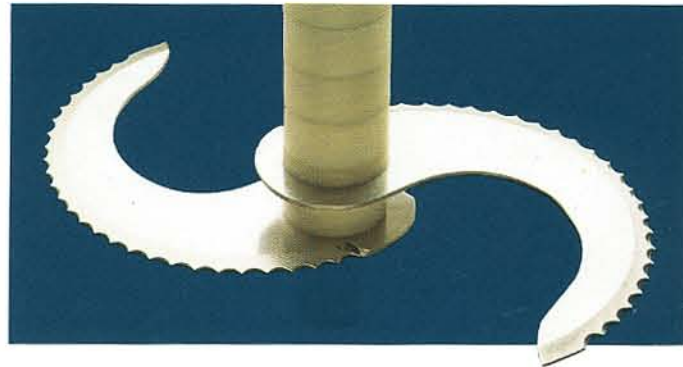

Speed as a guarantee of quality and economy

All the operations which can be done with the Speedy Cutter are carried out in a time varying between 20 seconds and maximum of 5 minutes. This high speed, not only prevents overheating of the product, but offers undeniable advantages both as regards the quality and the appearance of the food which, being less exposed to the atmosphere during processing, is not subject to deterioration or oxidation, so that improved hygiene is guaranteed. In addition it ensures considerable savings of time and labour, thanks to the high capacity of the Speedy Cutter (up to 60 litres in model DS/3) and the extreme simplicity of operation.

Times and capacities

	Times	Capacity of models in kg		
		DS/1	DS/2	DS/3
Hamburgers	4'	3-4	5-6	10-11
Stuffings	3'	7	10	18
Mashed potato	45"	10	15	25
Chopped vegetables for frying	1'	10	15	25
Mayonnaise	5'	9	18	40
Bread crumbs	30"	2	4	8
Grated cheese	1'30"	4	6	10
Vegetable soup	4'	10	15	25
Whips	1'	10	15	25

Technology at the service of productivity and safety

The specific experience and technology of Nilma have made the Speedy Cutter extremely simple, practical and also efficient to use. All you have to do is place the ingredients in the bowl, close the lid and start up the machine at the speed appropriate to the job. The Speedy Cutter is tightly sealed and can therefore be used without difficulty for liquid and semi-liquid products. The transparent lid enables the work to be observed at all times without interruption. When the work is done, the bowl tips to facilitate the removal of the product and the knife comes out easily for cleaning. In addition the parts which come in contact with the product are made of stainless steel 18/10 to guarantee maximum hygiene. Finally there are special safety devices to prevent accidents to the operator.

The processing times and quantities shown in the table may vary depending on the quality of the product, its temperature and weight, and the amount of processing which is required.



SPEEDY CUTTER

Universal food processor



FEATURES

DESIGN FEATURES

- Frame made of stainless steel 18/10 equipped with vibration absorbing rubber feet.
- Bowl made of satin finished stainless steel 18/10 which tips to facilitate emptying of product.
- Levers to tip and hold the bowl in the required position.
- Lid, hinged on right hand side, equipped with seal, handle and clamp.
- Knife group made up of one removable support and two crescent shaped serrated blades made of treated stainless steel.
- Equipped with hole for the introduction of spices or liquids during the processing.

SPECIFICATIONS

- Wall-mounted, water-tight power board, equipped with protection against motor overheating.
- Low-voltage 24 V control panel, made up of: low-speed button (1400 rpm), high-speed button (2800 rpm) and power indicator.
- Safety device to prevent machine from starting up with lid open and to stop it if lid is opened.
- Three-phase, 230 or 400 V, non-commutable, high power motor, with two speeds (1400-2800 rpm), protected externally by a stainless steel case.

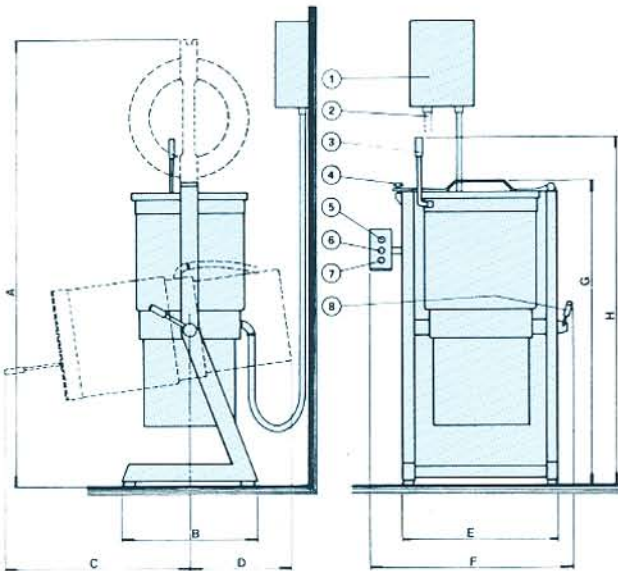

	DS/1	DS/2	DS/3
Max. bowl capacity ltrs	23	32	60
Processing speed rpm	1400-2800	1400-2800	1400-2800 Electric
Electric connection	230/400.3.50+E	230/400.3.50+E	230/400.3.50+E
Max. installed power kW	3,5	4,4	5,9
Weight of the machine kg	59	68	99

DIMENSIONS

	DS/1	DS/2	DS/3
A	1.420	1.500	1.600
B	470	470	510
C	380	450	520
D	350	370	390
E	470	510	590
F	675	715	790
G	985	1.000	1.160
H	1.090	1.140	1.200

KEY

- 1) Wall-mounted power board
- 2) Electric connection
- 3) Tipping lever
- 4) Lid locking knob
- 5) High speed button
- 6) Power indicator
- 7) Low speed button
- 8) Bowl locking lever



LA SCIENZA DELLE GRANDI CUCINE

NILMA SpA - Via E. Zacconi 24/A - 43100 Parma - Tel. +39 0521 785241 - Fax +39 0521 273050 - E-mail: export@nilma.it - Home Page: www.nilma.it
 Manufactured by NILMA s.p.a. - Italy - The factory reserves the right to make all the necessary alterations and technical improvements without notice